

100M/1000M SFP Optical Transceiver with SGMII Interface

TGM-1110-311I(C)

Features

- Operating data rate at 125Mbps or 1.25 Gbps
- Distance up to 10km
- Single 3.3V Power supply and TTL Logic Interface
- Duplex LC Connector Interface
- Hot Pluggable
- Compliant with MSA SFP Specification SFF-8472
- Compliant with IEEE 802.3
- Operating Case Temperature: -5 ~ +75deg C or -40 ~ +85deg C

Product Description

The SGMII Series optical transceivers are high performance, cost effective modules. They offer the customer a range of design options, including optional DDMI, standard temperature ranges. They are designed to provide 125Mb/s and 1.25 GB/s optical link in Gigabit Ethernet switches. These transceivers are qualified in accordance with GR-468-CORE.

Ordering Information

Part Number	Data Rate	Laser	DDMI (Y/N)	Case Operating Temperature	Fiber Type	Optical Interface	Distance (Km)
TGM-1110-311C	125M/1.25G	1310nm-FP	Yes	-5°C~+70°C	SMF	LC	10
TGM-1110-311I	125M/1.25G	1310nm-FP	Yes	-40°C~+85°C	SMF	LC	10

Regulatory Compliance

Feature	Standard	Performance
Electrostatic Discharge (ESD) to the Electrical Pins	MIL-STD-883G Method 3015.7	Class 1C (>1000 V)
Electrostatic Discharge to the enclosure	EN 55024:1998+A1+A2 IEC-61000-4-2 GR-1089-CORE	Compliant with standards

Electromagnetic Interference(EMI)	FCC Part 15 Class B EN55022:2006 CISPR 22B :2006 VCCI Class B	Compliant with standards Noise frequency range: 30MHz to 6 GHz. Good system EMI design practice required to achieve Class B margins. System margins depend on customer host board and chassis design.
Immunity	EN 55024:1998+A1+A2 IEC 61000-4-3	Compliant with standards.1kHz sine-wave, 80% AM,from 80 MHz to 1 GHz. No effect on transmitter/receiver performance is detectable between these limits.
Laser Eye Safety	FDA 21CFR 1040.10 and 1040.11 EN (IEC) 60825-1:2007 EN (IEC) 60825-2:2004+A1 EN(IEC)60950-1:2006+A1+A11+A12	CDRH compliant and Class I laser product. TUV Certificate No. R50271605
Component Recognition	UL and CUL UL60950-1:2007	UL file No. E344594 (CB:JPTUV-053877)
RoHS2.0	2011/65/EU	Compliant with standards

Note: For update of the equipment and strict control of raw materials, Telesail has the ability to supply the customized products since Sep.2008, which meets the requirements of RoHS6 (Restrictions on use of certain Hazardous Substances) of European Union. In light of item 5 in RoHS exemption list of RoHS Directive 2002/95/EC, Item 5: Lead in glass of cathode ray tubes, electronic components and fluorescent tube
In light of item 13 in RoHS exemption list of RoHS Directive 2005/747/EC, Item 13: Lead and cadmium in optical and filter glass. The three exemptions are being concerned for Telesail transceivers, because Telesail transceivers use glass, which may contain Pb, for components such as lenses, windows, isolators, and other electronic components

Absolute Maximum Ratings

Parameter	Symbol	Min	Max	Unit
Storage Temperature	TS	-40	+85	°C
Supply Voltage	VCC	0	+4	V
Operating Humidity		5	95	%

Note: Exceeding any one of these values may destroy the device permanently.

Recommended Operating Conditions

Parameter	Symbol	Min	Typical	Max	Unit	Notes
Operating Case Temperature	Tc	-5		70	°C	
Power Supply Voltage	VCC	3.14	3.3	3.47	V	
Bit Rate	100BASE		125		Mbps	
	1000BASE	1.25	Gbps			
Supply Current	Icc			450	mA	

Performance Specifications – Electrical

Parameter	Symbol	Min	Typ.	Max	Unit	Notes
Transmitter						
CML Inputs(Differential)	Vin	500		2400	mVpp	AC coupled inputs
Input Impedance (Differential)	Zin		100		ohm	Rin > 100 ohms @ DC
Tx_DISABLE Input Voltage – High		2		Vcc	V	

Tx_DISABLE Input Voltage – Lo	0	0.8	V
Tx_FAULT Output Voltage – High	2	Vcc	V
Tx_FAULT Output Voltage – Low	0	0.8	V
Receiver			
CML Outputs (Differential)	Vout	700	1600 mVpp AC coupled outputs
Output Impedance (Differential)	Zout	100	ohm
Rx_LOS Output Voltage – High	2		V OC output, should be pull up with 4.7K – 10 K Ω on the host board
Rx_LOS Output Voltage – Low	0	0.5	V
MOD_DEF (0:2)	VOH	2.5	V With Serial ID
	VOL	0	0.5 V

I/O Timing for Control & Status Functions Timing

Parameter	Symbol	Min	Typ.	Max	Unit
TX Disable Assert Time	t_off			10	us
TX_DISABLE Negate Time	t_on			1	ms
Time to initialize, include reset of TX_FAULT	t_init			300	ms
TX Fault Assert Time	t_fault			100	us
TX Disable to reset	t_reset	10			us
LOS Assert Time	t_loss_on		100		us
LOS De-Assert Time	t_loss_off		100		us

Performance Specifications – Optical

TGM-1110-311I(C) (1310nm, 10km, FP-LD, PINTIA)

Parameter	Symbol	Min	Typ.	Max	Unit	Note
Transmitter						
Centre Wavelength	λ_c	1280	1310	1340	nm	
Spectral Width* ^{Note4}	$\Delta\lambda$			4	nm	FP-LD
Average Output Power	100BASE	P _{OUT}	-15	-8	dBm	
	1000BASE		-9	-3		
Extinction Ratio	ER	9			dB	
Average Power of OFF Transmitter	P _{OFF}			-45	dBm	
Output Optical Eye	Compliant with IEEE 802.3ah-2004					
Receiver						
Centre Wavelength	λ_c	1200	1600		nm	
Sensitivity* ^{Note5}	100BASE	P _{IN}		-28	dBm	
	1000BASE			-22		
Receiver Overload	Overload	-3			dBm	
Optical Return Loss		12			dB	
LOS Assert	100BASE	LOSA	-45		dBm	
	1000BASE		-35			
LOS De-Assert	100BASE	LOSD		-30	dBm	
	1000BASE			-25		
LOS Hysteresis		0.5	4		dB	

Note4: VSCEL LD and FP LD measured spectral width RMS, DFB LD measured spectral width -20dB.

Note5: Minimum average optical power measured at the BER less than 1E-12@pattern is PRBS27-1@ER=9dB.

SFP Transceiver Electrical Pad Layout

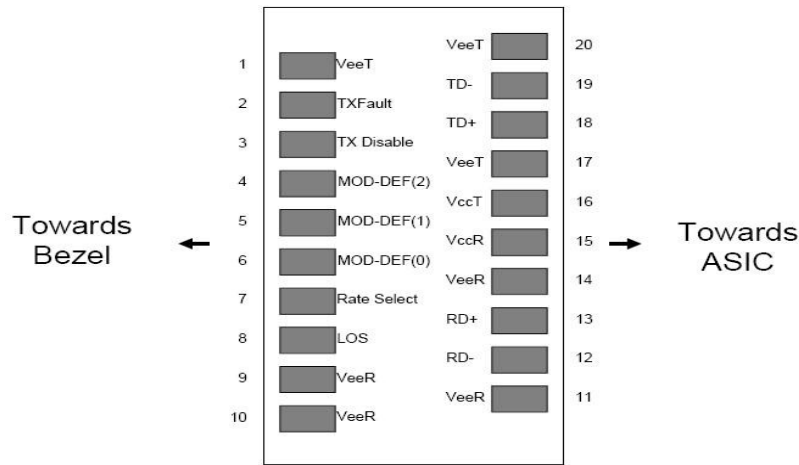

Diagram of Host Board Connector Block Pin Numbers and Names

Pin Function Definitions

Pin Num.	Name	Function	Plug Seq.	Notes
1	VeeT	Transmitter Ground	1	Note 10
2	TX Fault	Transmitter Fault Indication	3	Note 6
3	TX Disable	Transmitter Disable	3	Note 7, Module disables on high or open.
4	SDA	Module Definition 2	3	2-wire Serial Interface Data Line.
5	SCL	Module Definition 1	3	2-wire Serial Interface Clock.
6	MOD-ABS	Module Definition 0	3	Note 8
7	RS0	RX Rate Select (LVTTTL).	3	NC. Function not available
8	LOS	Loss of Signal	3	Note 9
9	RS1	TX Rate Select (LVTTTL).	1	NC. Function not available
10	VeeR	Receiver Ground	1	Note 10
11	VeeR	Receiver Ground	1	Note 10
12	RD-	Inv. Received Data Out	3	Note 11
13	RD+	Received Data Out	3	Note 12
14	VeeR	Receiver Ground	1	Note 10
15	VccR	Receiver Pow	2	3.3V ± 5%, Note 12
16	VccT	Transmitter Power	2	3.3V ± 5%, Note 12
17	VeeT	Transmitter Ground	1	Note 10
18	TD+	Transmit Data In	3	Note 13
19	TD-	Inv. Transmit Data In	3	Note 13
20	VeeT	Transmitter Ground	1	Note 10

Note6: TX Fault is an open collector/drain output, which should be pulled up with a 4.7K – 10K_Ω resistor on the host board. Pull up voltage between 2.0V and VccT/R+0.3V. When high, output indicates a laser fault of some kind. Low indicates normal operation. In the low state, the output will be pulled to < 0.8V.

Note7: TX disable is an input that is used to shut down the transmitter optical output. It is pulled up within the module with a 4.7K – 10 K_Ω resistor. Its states are: Low (0 – 0.8V): Transmitter on (>0.8, < 2.0V): Undefined. High (2.0 – 3.465V): Transmitter Disabled. Open: Transmitter Disabled.

Note8: Module Absent, connected to VeeT or VeeR in the module.

Note9: LOS (Loss of Signal) is an open collector/drain output, which should be pulled up with a 4.7K –10K_Ω resistor. Pull up voltage between 2.0V and VccT/R+0.3V. When high, this output indicates the received optical power is below the worst-case receiver sensitivity (as defined by the standard in use). Low indicates normal operation. In the low state, the output will be pulled to < 0.8V.

Note10: The module signal ground contacts, VeeR and VeeT, should be isolated from the module case.

Note11: RD-/+ : These are the differential receiver outputs. They are AC coupled 100_Ω differential lines which should be terminated with 100_Ω (differential) at the user SERDES. The AC coupling is done inside the module and is thus not required on the host board.

Note12: VccR and VccT are the receiver and transmitter power supplies. They are defined as 3.3V ±5% at the SFP connector pin. Maximum supply current is 300mA. Inductors with DC resistance of less than 1 ohm should be used in order to maintain the required voltage at the SFP input pin with 3.3V supply voltage. When the recommended supply-filtering network is used, hot plugging of the SFP transceiver module will result in an inrush current of no more than 30mA greater than the steady state value. VccR and VccT may be internally connected within the SFP transceiver module.

Note13: TD-/+ : These are the differential transmitter inputs. They are AC-coupled, differential lines with 100_Ω differential termination inside the module. The AC coupling is done inside the module and is thus not required on the host board.

Digital Diagnostic Functions

- 1) SFP transceiver supports the 2-wire serial communication protocol as defined in SFP MSA: in which defines a 256-byte memory map in EEPROM at 8 bit address 1010000X (A0h). The digital diagnostic monitoring interface is assigned with 8 bit address 1010001X (A2h). Additionally, SFP transceivers provide a unique digital diagnostic monitoring interface (DDMI), which allows real-time access to product operating parameters such as transceiver supply voltage, transceiver temperature, transmitted optical power, laser bias current and received optical power. It also defines alarm and warning threshold, which alerts end-users when particular operating parameters are outside of factory setting.
- 2) When the serial protocol is activated, the serial clock signal (SCL, Mod Def 1) is generated by the host. The positive edge clocks data into those segments of the EEPROM that are not write-protected. The negative edge clocks data from the SFP transceiver. The serial data signal (SDA, Mod Def 2) is bi-Directional for serial data transfer. The host uses SDA in conjunction with SCL to mark the start and end of serial protocol activation. The memories are organized as a series of 8-bit data words that can be addressed individually or sequentially.

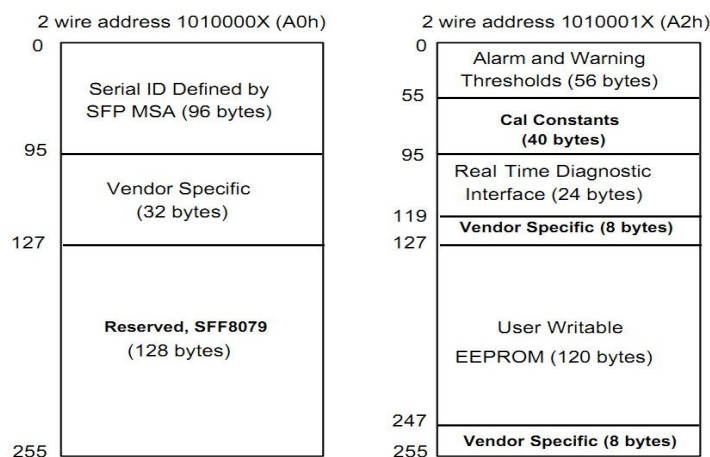

Digital Diagnostic Monitoring Specifications

- 1) Additionally, SFP transceivers TGM-xxxx-xx(1)C(I) provide a unique digital diagnostic monitoring interface (DDMI) be assigned with 8 bit address 1010001X (A2h) as defined in SFP MSA , which allows real-time access to product operating parameters such as transceiver supply voltage, transceiver temperature, transmitted optical power, laser bias current and received optical power. It also defines alarm and warning threshold, which alerts end-users when particular operating parameters are outside of factory setting.

- 2) Digital diagnostics for the TGM-xxxx-xx(1)C(I) are internally calibrated by default. Calibration and alarm/warning threshold data is written during device manufacturing.

Monitor accuracy				
Parameter	Min	Typ	Max	Units
Internally measured transceiver temperature			±3	°C
Internally measured transceiver supply voltage			±3%	V
Measured TX bias current			±10	%
Measured TX output power			±3	dB
Measured RX received average optical power			±3	dB

Dynamic range for operation					
Parameter	H-Alarm	H-warning	L-Warning	L- Alarm	Units
Internally measured transceiver temperature	+85	80	0	-5	°C
Internally measured transceiver supply voltage	3.9	3.6	3.0	2.7	V
Measured TX bias current	100	80	2	1	mA
Measured TX output power	Pout_max+1	Pout_max	Pout_min	Pout_min-1	dBm
Measured RX received average optical power	Overload+1	Overload	P _{IN}	P _{IN} -2	dBm

Note: TGM-xxxx-xx(1)C(I) provides an EEPROM addressed 101000X (A0h) as defined in SFP MSA, and only TGM-xxxx-xx(1)C(I) is compliant with digital diagnostic monitoring interface (DDMI) be assigned with 8 bit address 1010001X (A2h)

Recommended Circuit

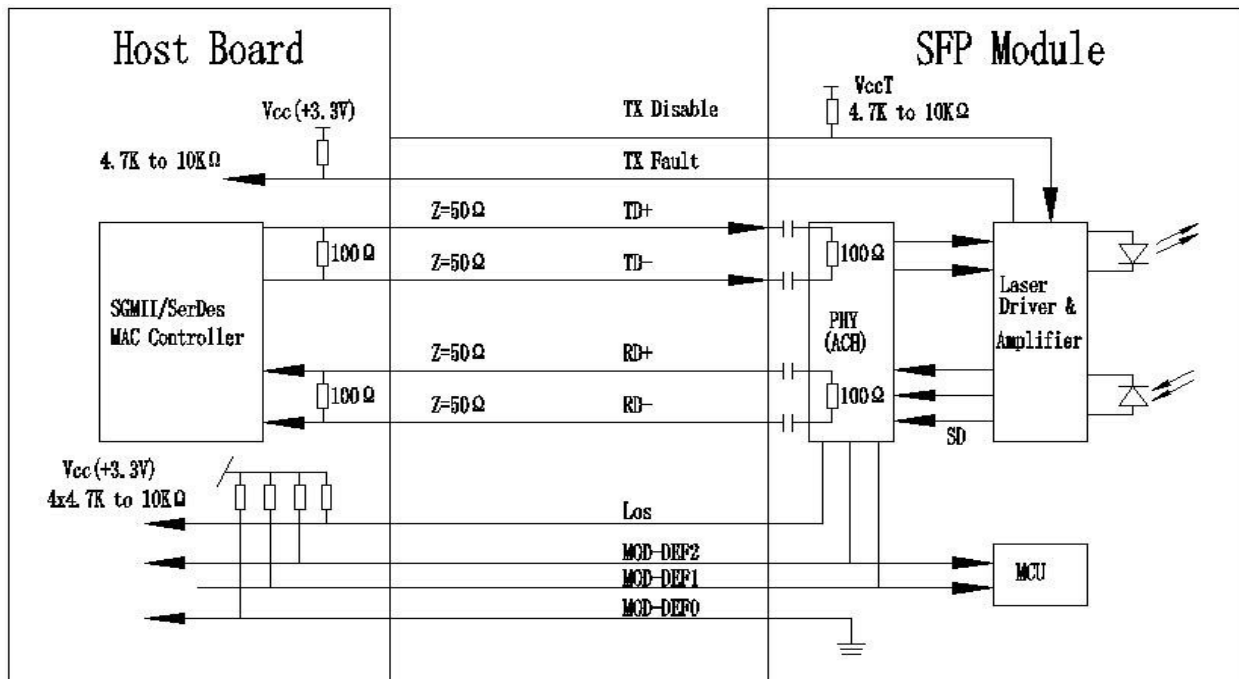

Mechanical Dimension

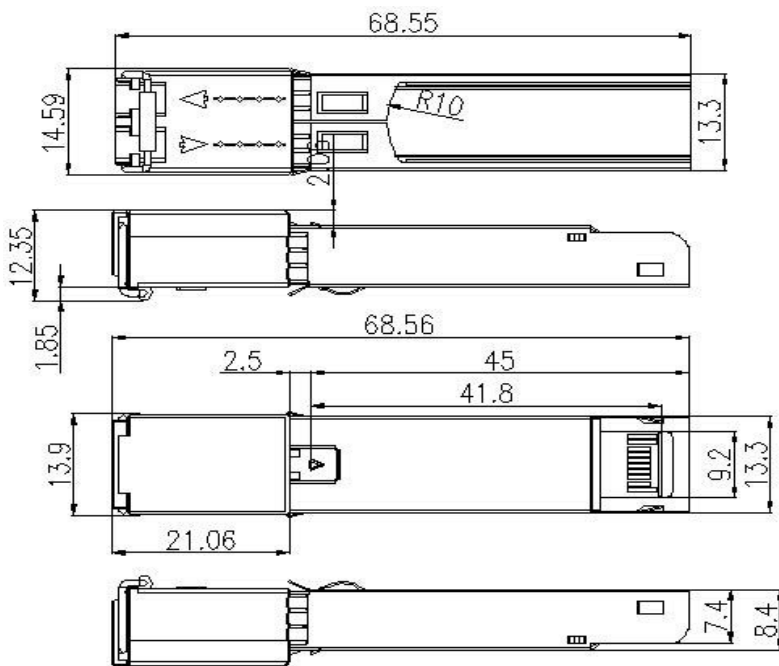

Unit:mm

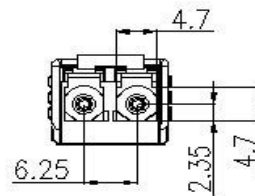
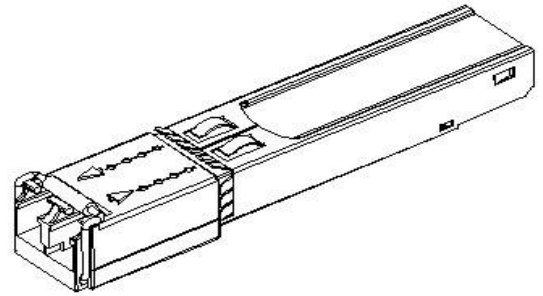

Eye Safety

This single-mode transceiver is a Class 1 laser product. It complies with IEC-60825 and FDA 21 CFR 1040.10 and 1040.11. The transceiver must be operated within the specified temperature and voltage limits. The optical ports of the module shall be terminated with an optical connector or with a dust plug.

Obtaining Document

You can visit our website: <http://www.telesail.com>

Or contact Telesail Technology Inc. listed at the end of the documentation to get the latest document.

Add: #No.3 Sichuan Str.,Shiyan 442024,Hubei Province. P.R. CHINA

Tel: (+86) 18588427281/Fax: (+86) 0719-8511538

E-mail: sale@telesail.com

<http://www.telesail.com>

© Copyright Telesail 2014 All rights reserve